



*Thirty years on and  
we're still leading the way...*





## *Generations past* **The Original Stairlift**

Mr Frederick Brooks made his first stairlift in 1973 for his wife Grace, a rheumatoid arthritis sufferer.

As a Daimler engineer, Mr Brooks put his many years' experience of craftsmanship and style into the original Brooks Lincoln Stairlift. Soon, people with mobility difficulties across the UK were contacting him to commission their own stairlift.

Thirty years later, Frederick Brooks' high standards remain. By combining today's advanced technology with a tradition of reliability and comfort, we guarantee that the Brooks Lincoln Stairlift will help you make the most of your home.

# *Brooks Stairlifts* **Make Life Easier**

*We remain true to our guiding principles of quality and care. Here are just a few of the features that set us apart.*

- *Easy to use controls*
- *Safety sensors*
- *Lockable swivel seat*
- *Slim fold-away design*
- *Fits to the stairs, not the wall*
- *Option to sit or stand*
- *12-month warranty*
- *FREE no obligation quotation*





Lockable on/off switch allows the user to prevent others (e.g. children) from using the lift. Diagnostic digital display informs the user of the status of the lift.



Five safety sensors on the footrest and carriage stop the lift automatically if any obstruction is encountered on the stairs.



Easy-to-use dual paddle controls which are operated by the lightest touch.



Swivel seat means no need for twisting to get on or off.

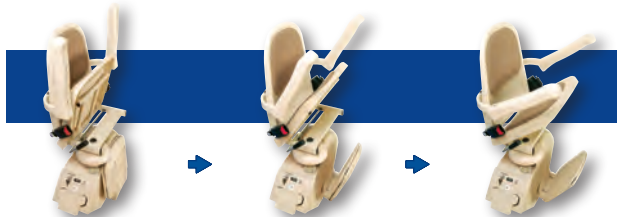

Folding seat and footrest allow full access to the staircase.

**Hinged Rail** eliminates any problem you may have with obstruction to a doorway at the foot of the stairs.



**Sit/Stand Stairlift** gives the user the choice whether to sit or stand.



**Perch Stairlift** is ideal for customers who may have trouble sitting or bending at the knee.

# Brooks provide **Professionalism & Care**

Safety and comfort come first at Brooks. The lift uses DC power packs that are automatically recharged when the lift is at rest. This means the lift is whisper quiet, incredibly smooth and will function even during a power cut.

Brooks Lincoln Stairlifts have slimline motors that provide a steady start / stop action and many years of faithful service. When you purchase a Brooks Lincoln stairlift, you are buying freedom – not costly maintenance.

Indeed, every part of the lift has been designed with you in mind. Each feature is the result of careful consideration in response to the requirements of the stairlift user. We listen, and then we produce the best solution.



*Remote control  
system for 'calling'  
the lift to your feet.*



*Decades of experience*  
**Quality And  
Craftsmanship**

*No unsightly  
structural work as the  
lift is secured to the  
stairs, not the wall.*

*Slim fitting lift  
ensures stairs can still  
be used by others.*

Brooks Lincoln Stairlifts are renowned for their low maintenance and high reliability. This is why we can offer a no-quibble warranty and complete peace of mind to all our customers. Our helpline and customer support network ensures that Brooks will always be there for you.

Every member of the Brooks team has been trained to the highest standard. From our customer support representatives to the engineer who installs your lift, our care and attention to detail is second to none.

For thirty years, we have provided the finest stairlifts to our customers. Ours is a heritage based on quality and service – a heritage you can trust. Join the thousands who associate 'Brooks' with excellence.

# Thirty years on and Still Leading The Way

## Specifications

Motor power	0.5 hp
Travel speed	No greater than 0.15 m/s
Method of drive	Rack and Pinion
Motor output torque	108 Nm
Power supply (battery)	24v DC
Maximum capacity	20 stones (127 kg)
Track	Extruded Aluminium
Mains supply	UK 240v, 50Hz Charger EC 220v, 50Hz Charger

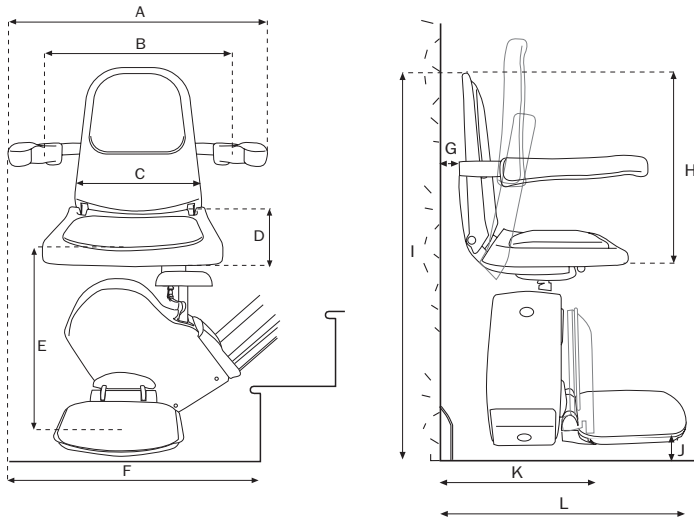

## Dimensions

<b>A</b> Width outside armrest	22"	560mm
<b>B</b> Width inside armrest	17.5"	445mm
<b>C</b> Width of backrest	14.5"	370mm
<b>D</b> Depth of seat	16"	410mm
<b>E</b> Top of footrest to top of seat	17.5"	445mm
<b>F</b> Required space from bottom of stair	26"	660mm
<b>G</b> Wall to seat width	1.5"	40mm
<b>H</b> Overall height of seat	19.5"	495mm
<b>I</b> Overall height	40"	1020mm
<b>J</b> Footrest surface to floor	4.5"	115mm
<b>K</b> Overall depth (folded)	13"	325mm
<b>L</b> Overall depth (footrest down)	23"	585mm

Brooks, in keeping with its policy of continual development, reserves the right to change specifications without notice. All measurements are approximate. Images are shown for illustrative purposes only.

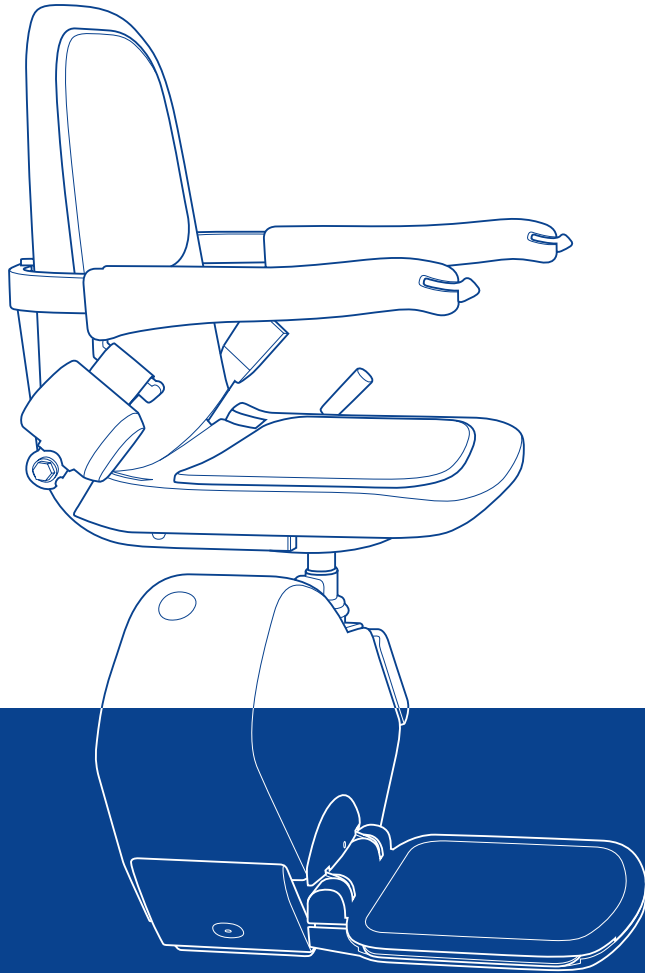

## *Make the most of your home with a Brooks Stairlift.*

Don't forget to ask about our extended warranty plans for your complete peace of mind. Brooks welcomes customer feedback to ensure our standards of service and quality remain second to none.

**CALL NOW** for friendly advice or to arrange your no-obligation meeting with one of our home mobility consultants. We look forward to speaking to you.

BRITISH STANDARD  
BS 5776  
1996

